

REV	DESCRIPTION	DATE	ECN #	APPR
A	INITIAL RELEASE	00-XXX-19	XXXXX	MM

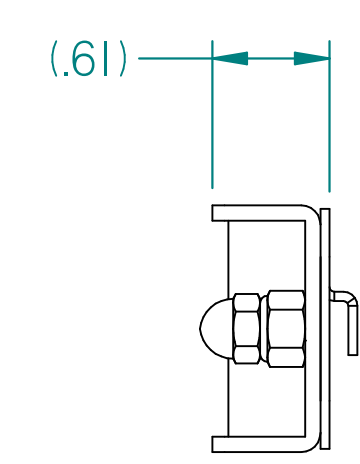
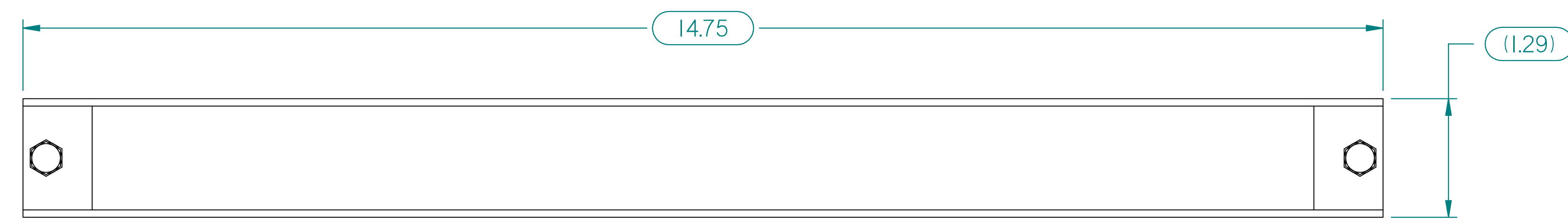
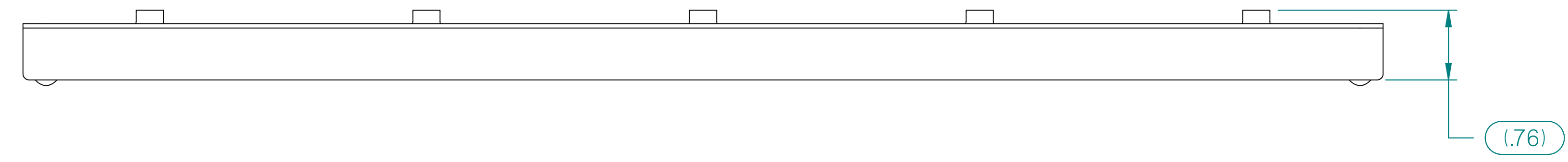

<p>THIS DOCUMENT CONTAINS PROPRIETARY INFORMATION OF MOPEC, AND MAY NOT BE COPIED IN WHOLE OR PART, AND NO USE SHALL BE MADE OF IT OTHER THAN FOR WHICH IT HAS BEEN SUBMITTED WITHOUT THE WRITTEN PERMISSION OF A MOPEC MANAGER</p> <p>MOPEC 2024</p>	<p>UNLESS OTHERWISE SPECIFIED ALL DIMENSIONS IN INCHES</p> <p>TOLERANCES</p> <table> <tr><td>0.0</td><td>± 0.1 in</td></tr> <tr><td>0.00</td><td>± 0.05 in</td></tr> <tr><td>0.000</td><td>± 0.010 in</td></tr> <tr><td>0.0000</td><td>± 0.0010 in</td></tr> </table> <p>ANGLES ±0.5°</p> <p>BREAK ALL CORNERS 0.063 X 45°</p> <p>ALL FILLET RADII R0.063 / 0.125 in</p> <p>INSPECT OVAL DIMENSIONS</p>	0.0	± 0.1 in	0.00	± 0.05 in	0.000	± 0.010 in	0.0000	± 0.0010 in	<p>MOPEC GROUP</p> <p>MORTECH</p>	<p>DRAWN BY: A SALAME</p> <p>DATE: 1/29/2020</p>	<p>PART NUMBER: AX015-A</p>
		0.0	± 0.1 in									
0.00	± 0.05 in											
0.000	± 0.010 in											
0.0000	± 0.0010 in											
<p>DRAWN TO: 3RD ANGLE PROJECTION</p>	<p>CHECKED BY: ---</p> <p>DATE: 1/29/2020</p>	<p>DESCRIPTION: PEGBOARD, MAGNETIC TOOL BAR</p>	<p>SIZE: A2</p> <p>FILE NAME: AX015-A.dft</p>									
			<p>APPROVED BY: M. McCLAIN</p> <p>DATE: 1/29/2020</p>	<p>SCALE: 1:1</p>								
			<p>DO NOT SCALE IF IN DOUBT ASK</p>	<p>SHEET 1 OF 2</p>								

AX015-A.dft

I 2 3 4 5 6 7 8 9 10 11

REV	DESCRIPTION	DATE	ECN #	APPR
A	INITIAL RELEASE	00-XXX-19	XXXXX	MM

A
B
C
D
E
F
G
H

A
B
C
D
E
F
G
H



Item Number	File Name (no extension)	Author	Quantity
I	S6789-A	jbourbeau	I

<p>THIS DOCUMENT CONTAINS PROPRIETARY INFORMATION OF MOPEC, AND MAY NOT BE COPIED IN WHOLE OR PART, AND NO USE SHALL BE MADE OF IT OTHER THAN FOR WHICH IT HAS BEEN SUBMITTED WITHOUT THE WRITTEN PERMISSION OF A MOPEC MANAGER</p> <p>MOPEC 2024</p>	<p>UNLESS OTHERWISE SPECIFIED ALL DIMENSIONS IN INCHES</p> <p>TOLERANCES</p> <table> <tr><td>0.0</td><td>± 0.1 in</td></tr> <tr><td>0.00</td><td>± 0.05 in</td></tr> <tr><td>0.000</td><td>± 0.010 in</td></tr> <tr><td>0.0000</td><td>± 0.0010 in</td></tr> </table> <p>ANGLES ±0.5°</p> <p>BREAK ALL CORNERS 0.063 X 45° ALL FILLET RADII R0.063 /0.125in INSPECT OVAL DIMENSIONS</p>	0.0	± 0.1 in	0.00	± 0.05 in	0.000	± 0.010 in	0.0000	± 0.0010 in	 	<p>DRAWN BY: A SALAME DATE: 1/29/2020</p>	<p>PART NUMBER: AX015-A</p>
		0.0	± 0.1 in									
		0.00	± 0.05 in									
0.000	± 0.010 in											
0.0000	± 0.0010 in											
<p>CHECKED BY: --- DATE: 1/29/2020</p>	<p>DESCRIPTION: PEGBOARD, MAGNETIC TOOL BAR</p>											
<p>APPROVED BY: M. McCLAIN DATE: 1/29/2020</p>	<p>SIZE: A2 FILE NAME: AX015-A.dft</p>											
<p>DRAWN TO 3RD ANGLE PROJECTION</p>	<p>SCALE: 1:1</p>	<p>DO NOT SCALE IF IN DOUBT ASK</p>	<p>SHEET 2 OF 2</p>									

I 2 3 4 5 6 7 8 9 10 11

AX015-A.dft