

| REV | DESCRIPTION | DATE | ECN # | APPR |
|-----|-----------------|-----------|-------|------|
| A | INITIAL RELEASE | 00-XXX-19 | XXXXX | MM |
| | | | | |
| | | | | |
| | | | | |

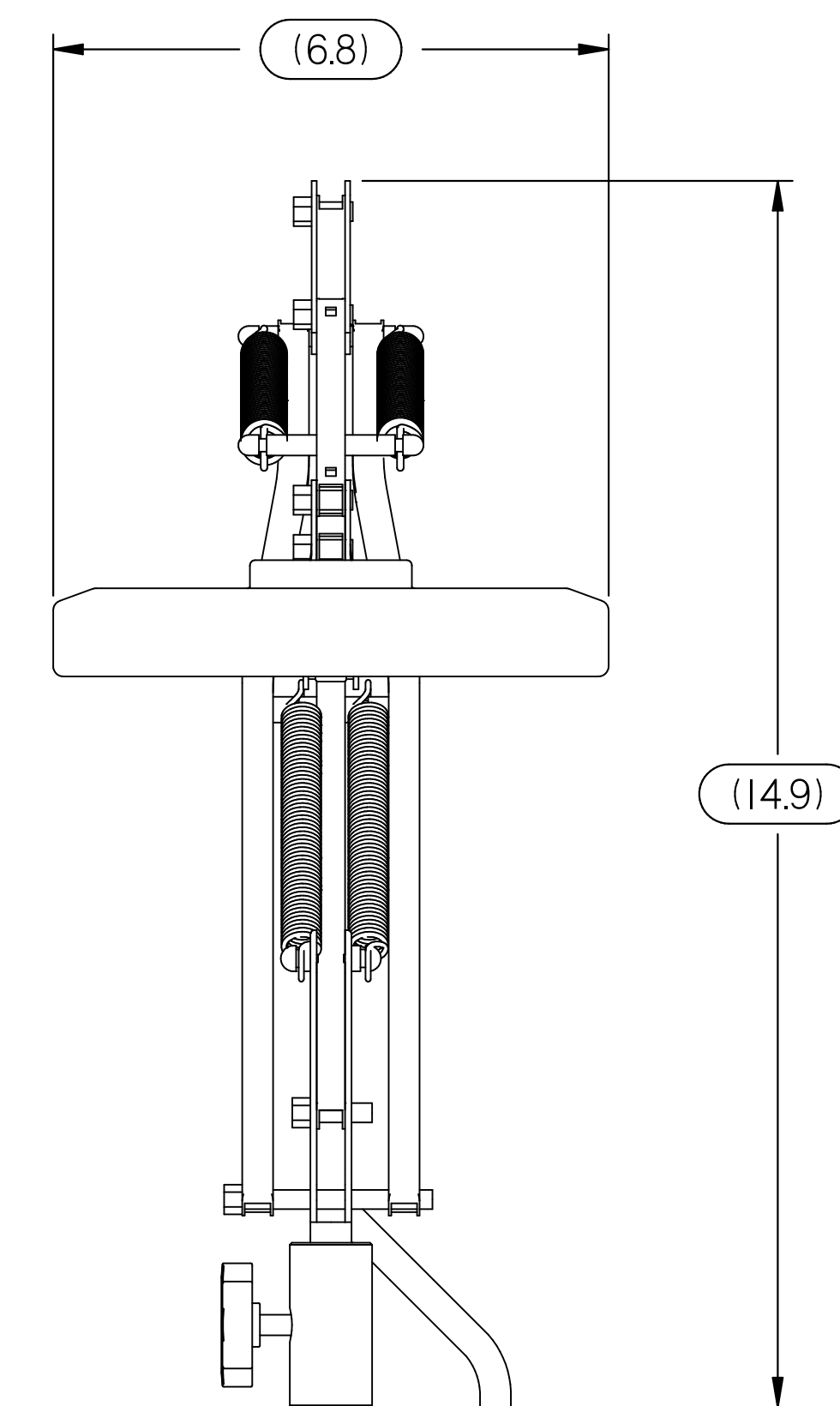
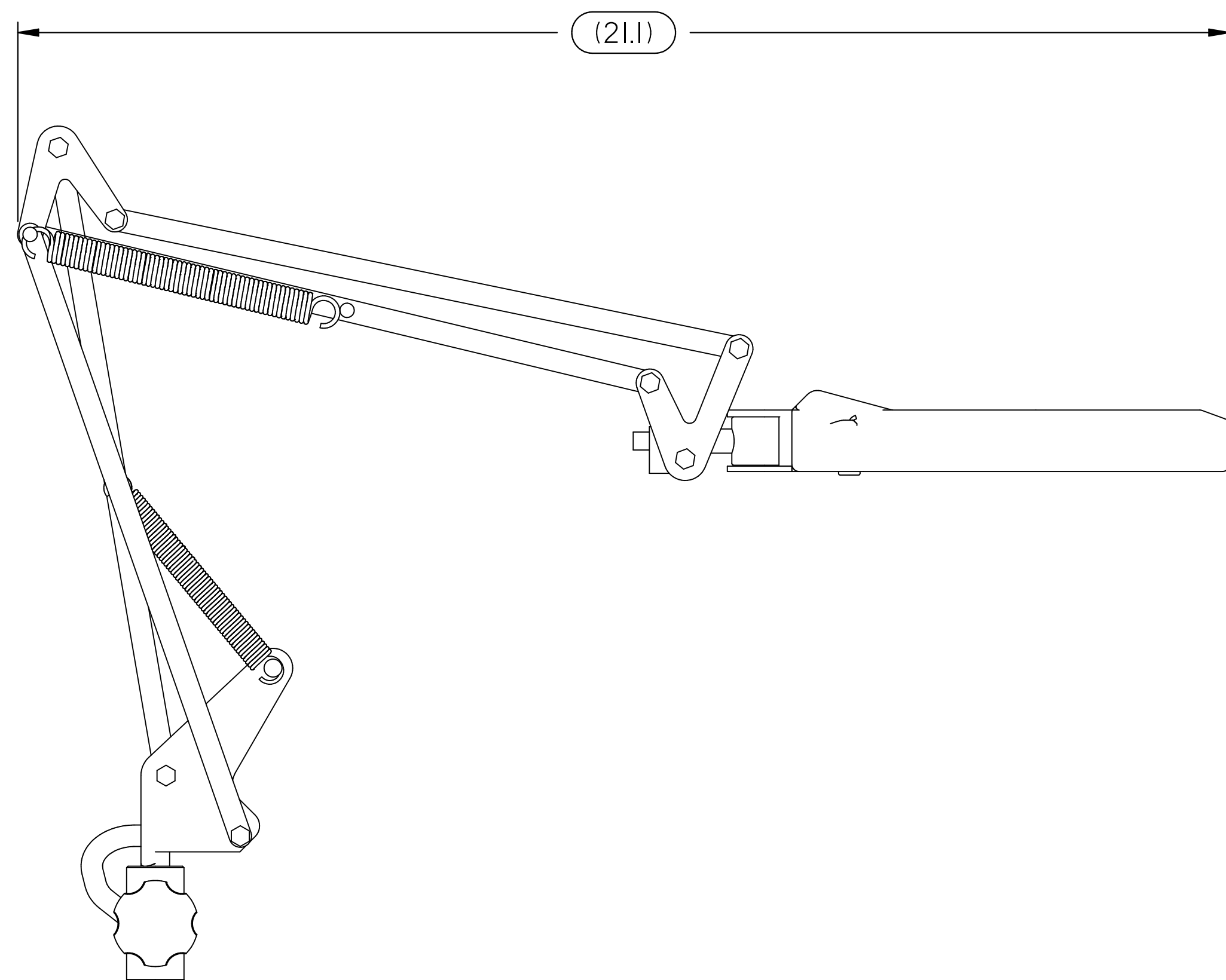
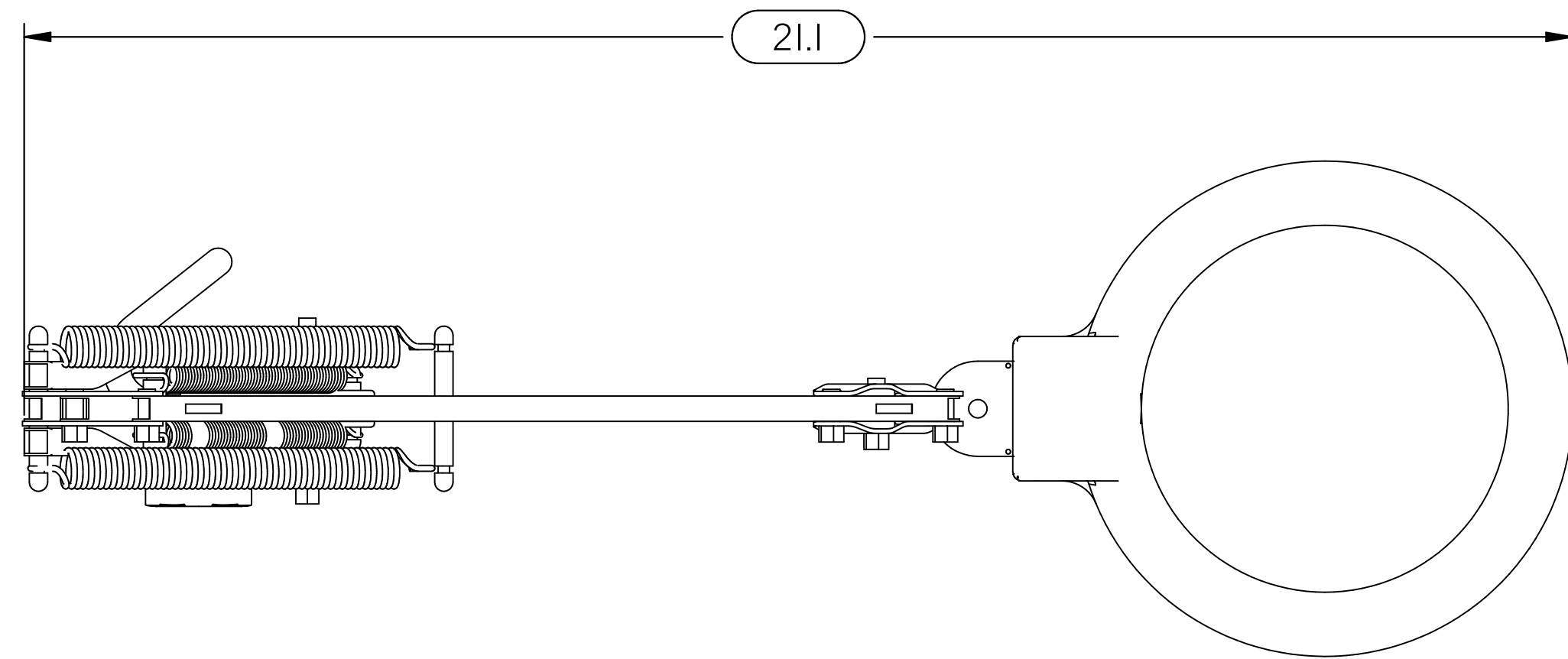

| | | | | |
|--|---|------|---|--|
| THIS DOCUMENT CONTAINS PROPRIETARY INFORMATION OF MOPEC, AND MAY NOT BE COPIED IN WHOLE OR PART, AND NO USE SHALL BE MADE OF IT OTHER THAN FOR WHICH IT HAS BEEN SUBMITTED WITHOUT THE WRITTEN PERMISSION OF A MOPEC MANAGER MOPEC 2025 | UNLESS OTHERWISE SPECIFIED ALL DIMENSIONS IN INCHES TOLERANCES 0.0 ± 0.1 in 0.00 ± 0.05 in 0.000 ± 0.010 in 0.0000 ± 0.0010 in ANGLES ± 0.5° BREAK ALL CORNERS 0.063 X 45° ALL FILLET RADII R0.063 /0.125in INSPECT OVAL DIMENSIONS | | DRAWN BY B. LAY DATE: 1/14/2025 | PART NUMBER AXI44-A |
| | | | CHECKED BY DATE: 1/14/2025 | DESCRIPTION SIZE: A2 FILE NAME: AXI44-A.dft SCALE: 1:2 |
| DRAWN TO 3RD ANGLE PROJECTION | | | APPROVED BY DATE: M.McCLAIN 1/14/2025 | DO NOT SCALE IF IN DOUBT ASK SHEET 1 OF 2 |

AX144-A.dft

I 2 3 4 5 6 7 8 9 10 11

| REV | DESCRIPTION | DATE | ECN # | APPR |
|-----|-----------------|-----------|-------|------|
| A | INITIAL RELEASE | 00-XXX-19 | XXXXX | MM |
| | | | | |
| | | | | |
| | | | | |

A
B
C
D
E
F
G
H

A
B
C
D
E
F
G
H



| Item Number | Quantity | File Name | Title | Material | Revision |
|-------------|----------|------------|-------|--|----------|
| I | I | PM0092.par | | RM0664, SHT, AL, 7GA, 48" X 120" 6061-T-6 | |

| | | | | |
|--|--|------|---|---|
| THIS DOCUMENT CONTAINS PROPRIETARY INFORMATION OF MOPEC, AND MAY NOT BE COPIED IN WHOLE OR PART, AND NO USE SHALL BE MADE OF IT OTHER THAN FOR WHICH IT HAS BEEN SUBMITTED WITHOUT THE WRITTEN PERMISSION OF A MOPEC MANAGER MOPEC 2025 | UNLESS OTHERWISE SPECIFIED ALL DIMENSIONS IN INCHES TOLERANCES 0.0 ± 0.1 in 0.00 ± 0.05 in 0.000 ± 0.010 in 0.0000 ± 0.0010 in ANGLES ±0.5° BREAK ALL CORNERS 0.063 X 45° ALL FILLET RADII R0.063 /0.125in INSPECT OVAL DIMENSIONS | | DRAWN BY B. LAY DATE 1/14/2025 | PART NUMBER AXI44-A |
| | | | CHECKED BY DATE --- 1/14/2025 | DESCRIPTION SIZE A2 FILE NAME AXI44-A.dft SCALE 1:1 |
| DRAWN TO 3RD ANGLE PROJECTION | | | APPROVED BY DATE: M.McCLAIN 1/14/2025 | DO NOT SCALE IF IN DOUBT ASK SHEET 2 OF 2 |

I 2 3 4 5 6 7 8 9 10 11

AX144-A.dft