

REV	DESCRIPTION	DATE	ECN #	APPR
A	INITIAL RELEASE	00-XXX-19	XXXXX	MM

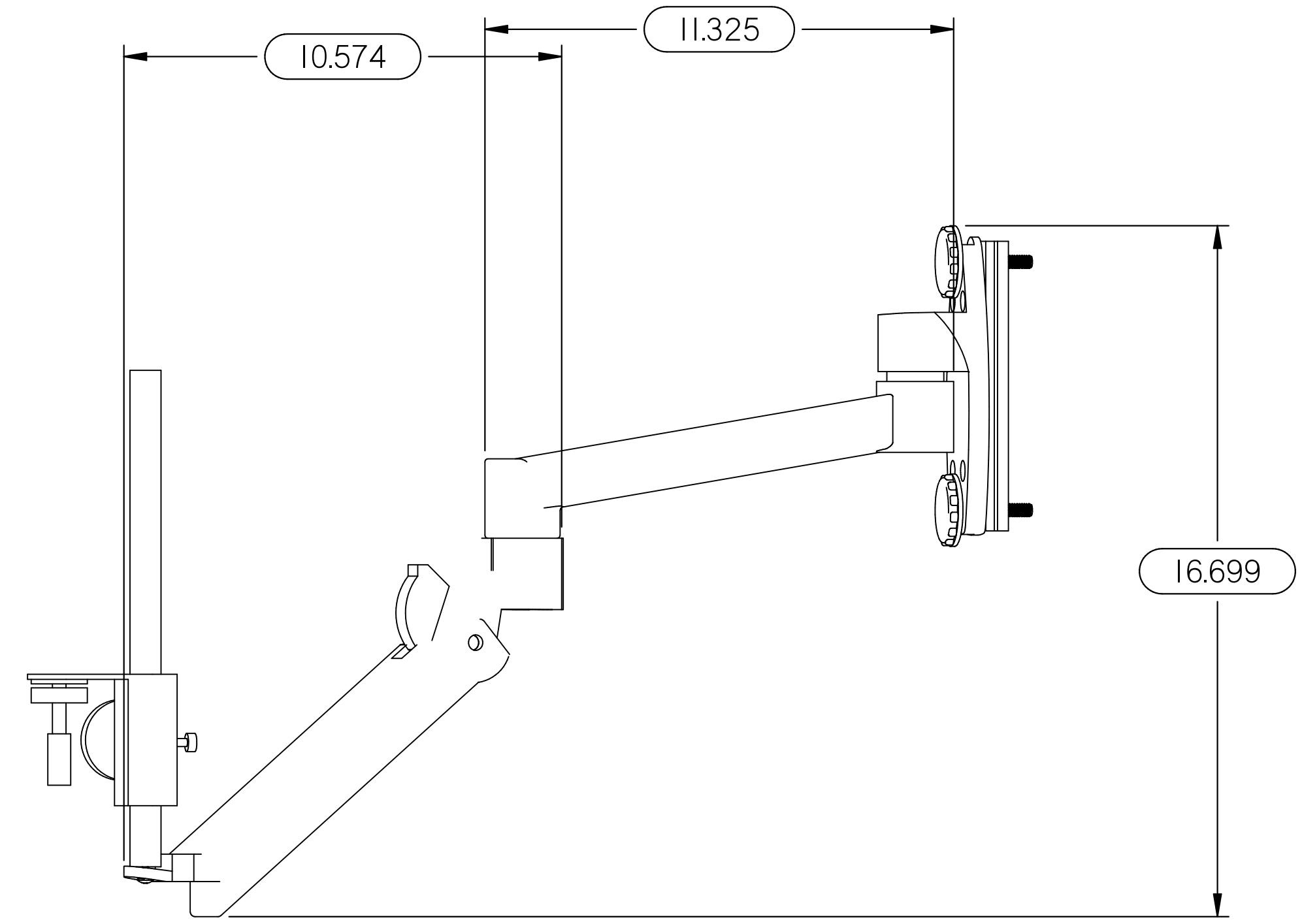
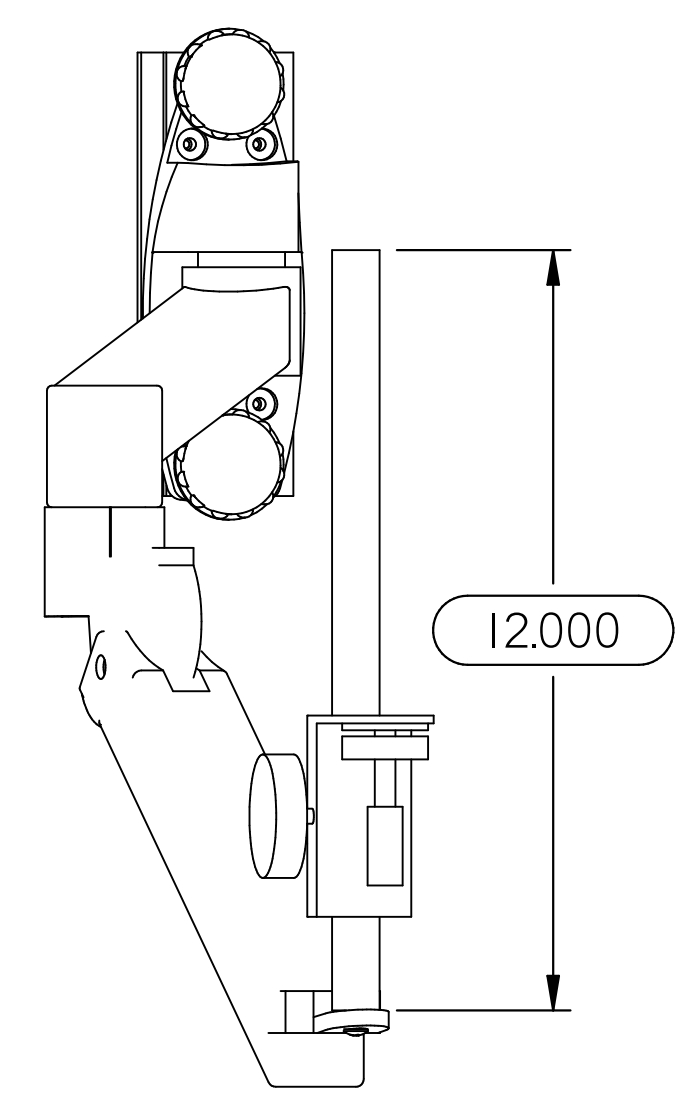
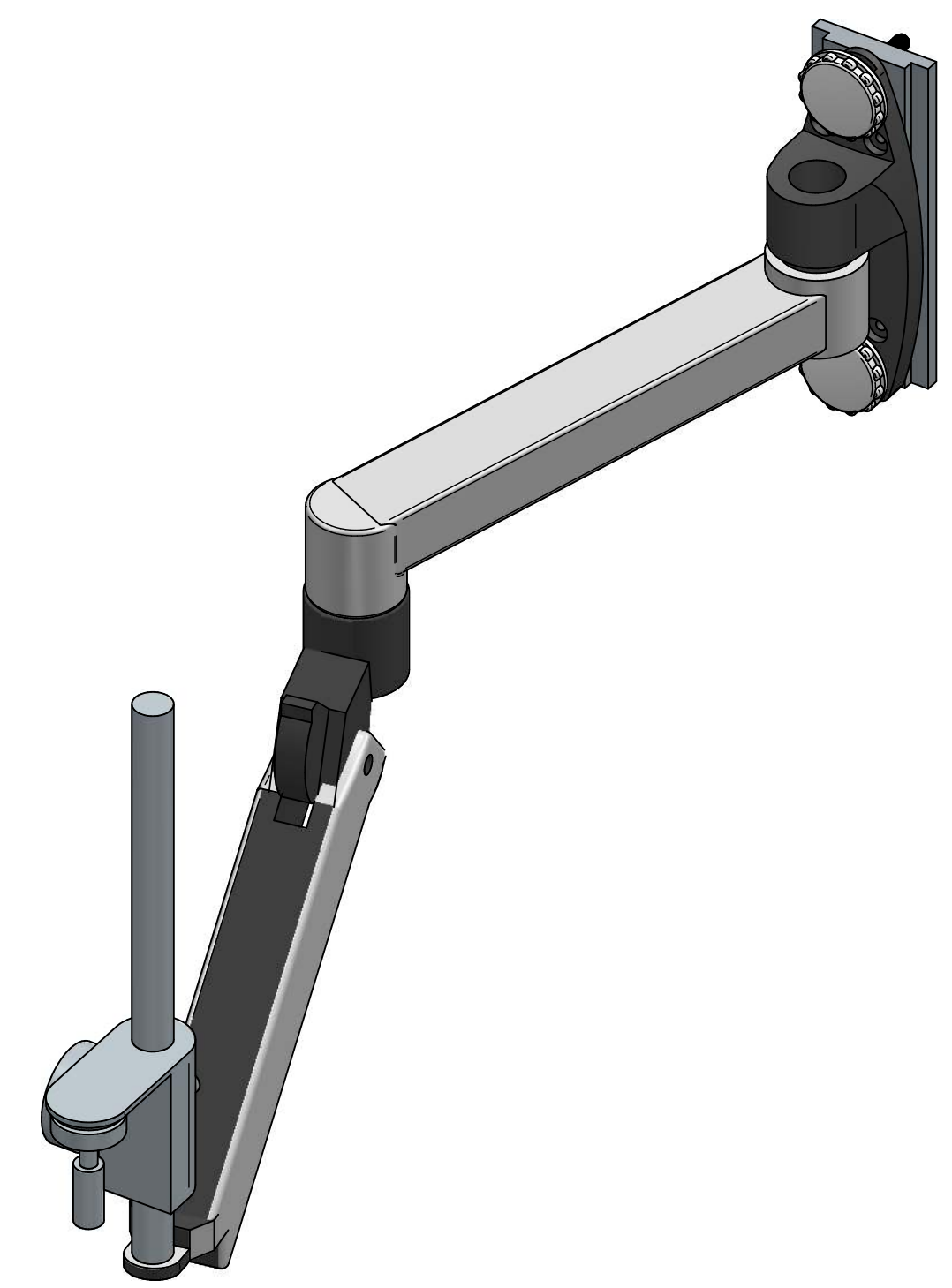
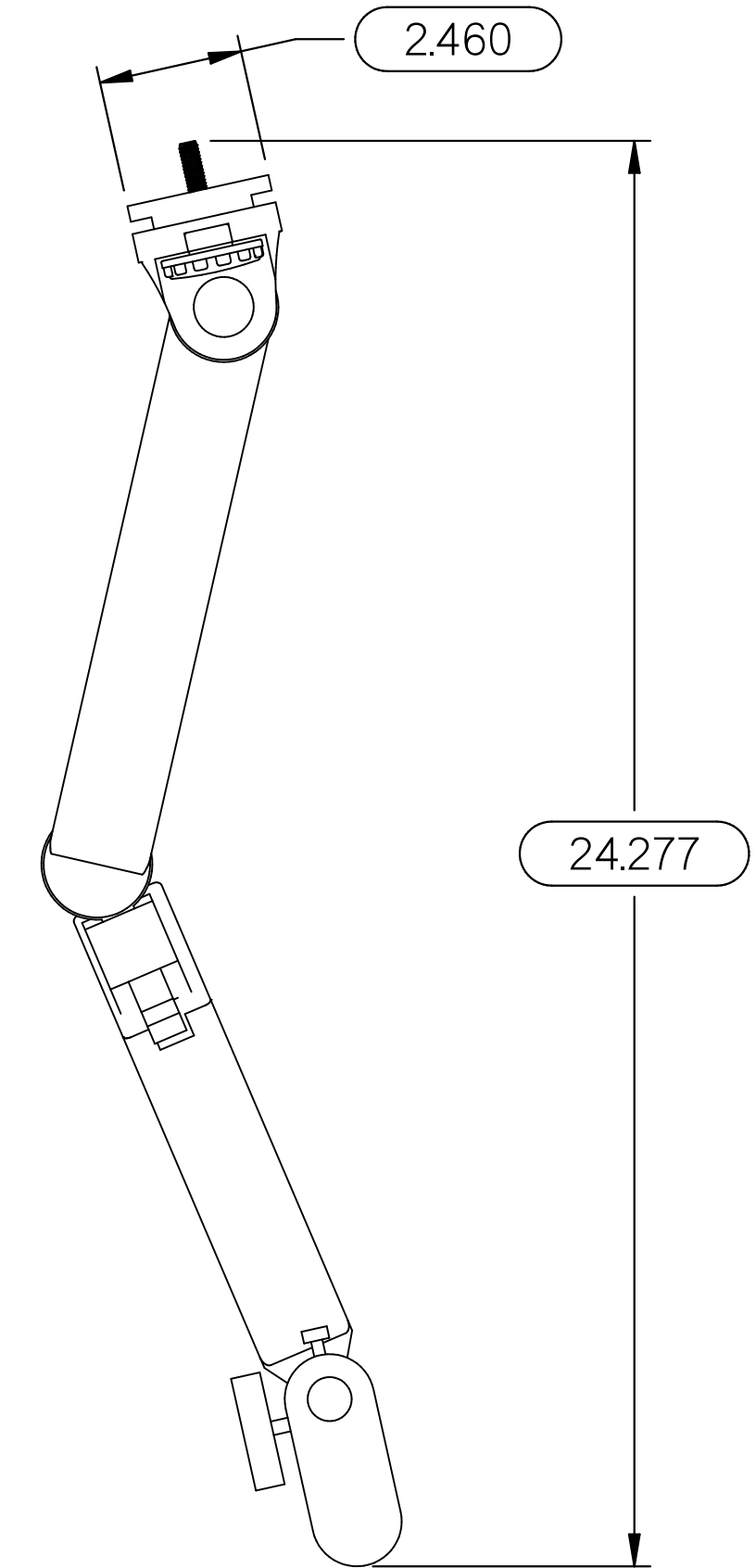

THIS DOCUMENT CONTAINS PROPRIETARY INFORMATION OF MOPEC, AND MAY NOT BE COPIED IN WHOLE OR PART, AND NO USE SHALL BE MADE OF IT OTHER THAN FOR WHICH IT HAS BEEN SUBMITTED WITHOUT THE WRITTEN PERMISSION OF A MOPEC MANAGER MOPEC 2024	UNLESS OTHERWISE SPECIFIED ALL DIMENSIONS IN INCHES TOLERANCES 0.0 ± 0.1 in 0.00 ± 0.05 in 0.000 ± 0.010 in 0.0000 ± 0.0010 in ANGLES ± 0.5° BREAK ALL CORNERS 0.063 X 45° ALL FILLET RADII R0.063 / 0.125 in INSPECT OVAL DIMENSIONS	  MOPEC MORTECH <small>MANUFACTURING</small>	DRAWN BY: B. LAY DATE: 9/22/2022 CHECKED BY: DATE: 9/22/2022 APPROVED BY: DATE: M. McCLAIN 9/22/2022	PART NUMBER: AXI33 DESCRIPTION: PATHCAM, MICRO CAMERA SIZE: A2 FILE NAME: AXI33.dft SCALE: 1:3.03 DO NOT SCALE IF IN DOUBT ASK	REV: A SHEET 1 OF 2
	MOPEC 2024		DRAWN TO 3RD ANGLE PROJECTION 	SHEET 1 OF 2	

\*AXI33.dft\*

REV	DESCRIPTION	DATE	ECN #	APPR
A	INITIAL RELEASE	00-XXX-19	XXXXX	MM

THREADED CAP

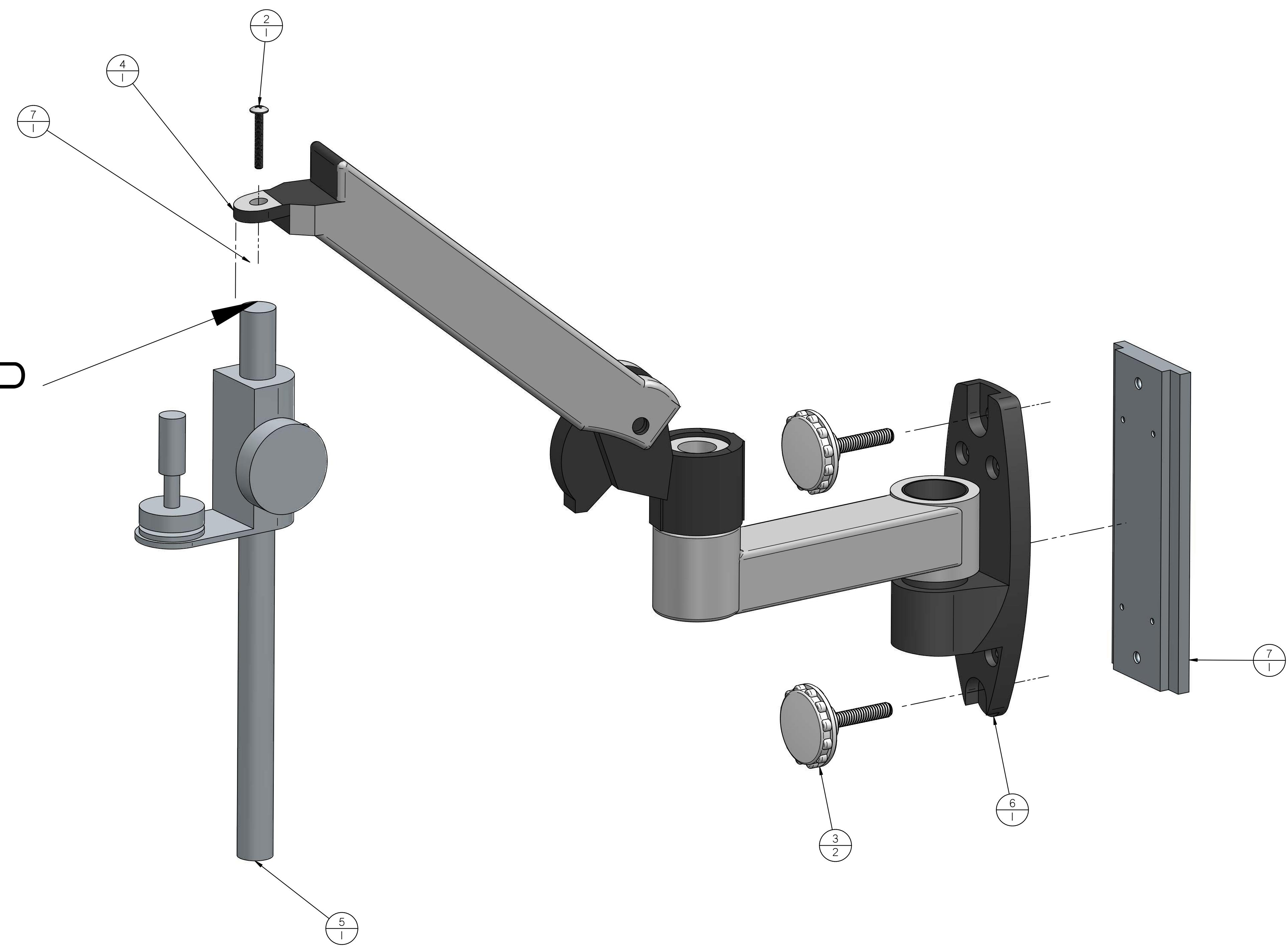

Item Number	Quantity	File Name	Title	Material
1	1	PB0007.par		
2	1	PB0082.par	SCREW - SS, 8-32 x 1-1/4"L, TRUSS PHILLIPS	McMaster-Carr#91770A201
3	2	PL0091.par	5/16"-18 x 1-1/2"L KNOB	Stainless steel
4	1	PM0354_AXI33-Aasm	MODIFIED PM0354 ASSY FOR AXI33	
5	1	PM0761.par	PM0761 MICROSCOPE STAND	
6	1	S6664-A.par	ERGOTRON "TRAILER HITCH"	Stainless steel
7	1	S6836-B.par	AX ACCESSORY MOUNT	RM0258, FLAT, AL, 1/2" X 2-1/2", 6061

THIS DOCUMENT CONTAINS PROPRIETARY INFORMATION OF MOPEC, AND MAY NOT BE COPIED IN WHOLE OR PART, AND NO USE SHALL BE MADE OF IT OTHER THAN FOR WHICH IT HAS BEEN SUBMITTED WITHOUT THE WRITTEN PERMISSION OF A MOPEC MANAGER  
MOPEC 2024

UNLESS OTHERWISE SPECIFIED ALL DIMENSIONS IN INCHES  
TOLERANCES 0.0 ± 0.1 in  
0.00 ± 0.05 in  
0.000 ± 0.010 in  
0.0000 ± 0.0010 in  
ANGLES ±0.5°  
BREAK ALL CORNERS 0.063 X 45°  
ALL FILLET RADII R0.063 /0.125in  
INSPECT OVAL DIMENSIONS

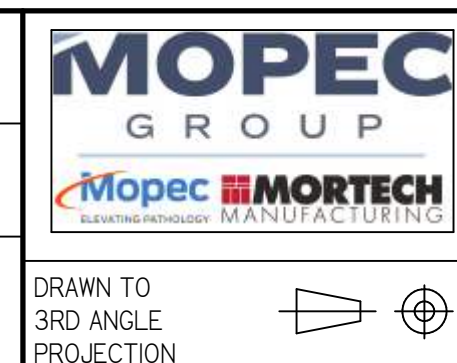

DRAWN BY B. LAY  
DATE 9/22/2022  
CHECKED BY  
DATE 9/22/2022  
APPROVED BY M. McCLAIN  
DATE 9/22/2022

PART NUMBER	AXI33
DESCRIPTION	PATHCAM, MICRO CAMERA
SIZE	A2
FILE NAME	AXI33.dft
SCALE	1:1.33
DO NOT SCALE IF IN DOUBT ASK	
SHEET 2 OF 2	

\*AXI33.dft\*